

VNA2 series

The VNA2 Series Vertical Jet Pumps are the industry standard deep well jet pumps for over-the-well “bolt-on” installations.

The VNA2 Series Jet Pumps include the pre-plumbed Aermotor external automatic regulator, pressure gauge, pressure switch, and a complete line of casing adapters to drive the 4” double pipe or 2” and 3” single pipe jet packages.

application

Water systems and sprinkling... for homes, farms and cottages.

specifications

Body – Rugged cast iron

Pump and Motor Shaft – 416 stainless steel

Impellers – Noryl®

Diffuser – Close-grained cast iron

Noryl® is a registered trademark of General Electric Co. PRO-Source™ is a trademark of WICOR Industries.



- ▶ **Automatic Pressure Regulator** – Faster-acting and quieter, design eliminates “hunting” for correct drive pressure. New improved stem and guide are precisely molded to assure efficient, trouble-free performance on all deep wells.
- ▶ **Quality Construction** – Precision-machined, close-grained cast iron pump body and base are specially treated to resist corrosion
- ▶ **Noryl® Impellers** – Precision molded for perfect balance, and ultra-smooth for highest performance and efficiency
- ▶ **Pressure Switch** – High quality. Differential and cut-in/cut-out pressure settings are adjustable
- ▶ **Motor Windings** – Superior insulation materials protect against excessive moisture and contaminants to ensure prolonged motor life
- ▶ **Mechanical Shaft Seal** – Precision lapped and highly polished carbon-ceramic, stainless steel construction. Internal design guarantees continuous water lubrication for maximum protection.
- ▶ **Dustproof Cover** – All electrical components are protected from dirt, dust and insects by a dustproof canopy. Ventilating air cannot contaminate vital switching components. This eliminates the most common cause of motor failure.
- ▶ **Balanced Rotor** – Rotor is die cast under high pressures for uniform performance and greater efficiency; dynamically balanced.
- ▶ **Heavy-duty Ball Bearings** – Permanently lubricated sealed bearings are extensively tested to ensure extended life and smooth, quiet operation
- ▶ **Pump and Motor Shaft** – One piece threaded shaft for positive impeller drive and alignment. Shaft is stainless steel for maximum corrosion resistance.

VNA2 series

ordering information

Catalog Number	HP	Description	Max. Press. Reg. Setting	Pipe Tapping Sizes			Motor Voltage	Approx. Wt. Lbs.
				Suct.	Drive	Disch.		
VNA2-100	1	Base Mounted Pump	60 PSI	1-1/4"	1-1/4"	1"	115/230	73
VNA2-150	1-1/2	Base Mounted Pump	85 PSI	1-1/4"	1-1/4"	1"	230	120
VNA2-200	2	Base Mounted Pump	95 PSI	1-1/4"	1-1/4"	1"	230	125

ADAPTER FLANGE

Catalog Number	Description	Used With
J216-26	1-1/4" x 1"	Offset single pipe, 4" double pipe through 3/4 HP
J216-27	1-1/4" x 1-1/4"	4" double pipe 1, 1-1/2 and 2 HP

NOTE: Order pump from ordering information table above. A Jet Package should be ordered with every VNA2 Series Pump. All installations require an appropriate size adapter flange or casing adapter if bolt-on feature is desired.

outline dimensions

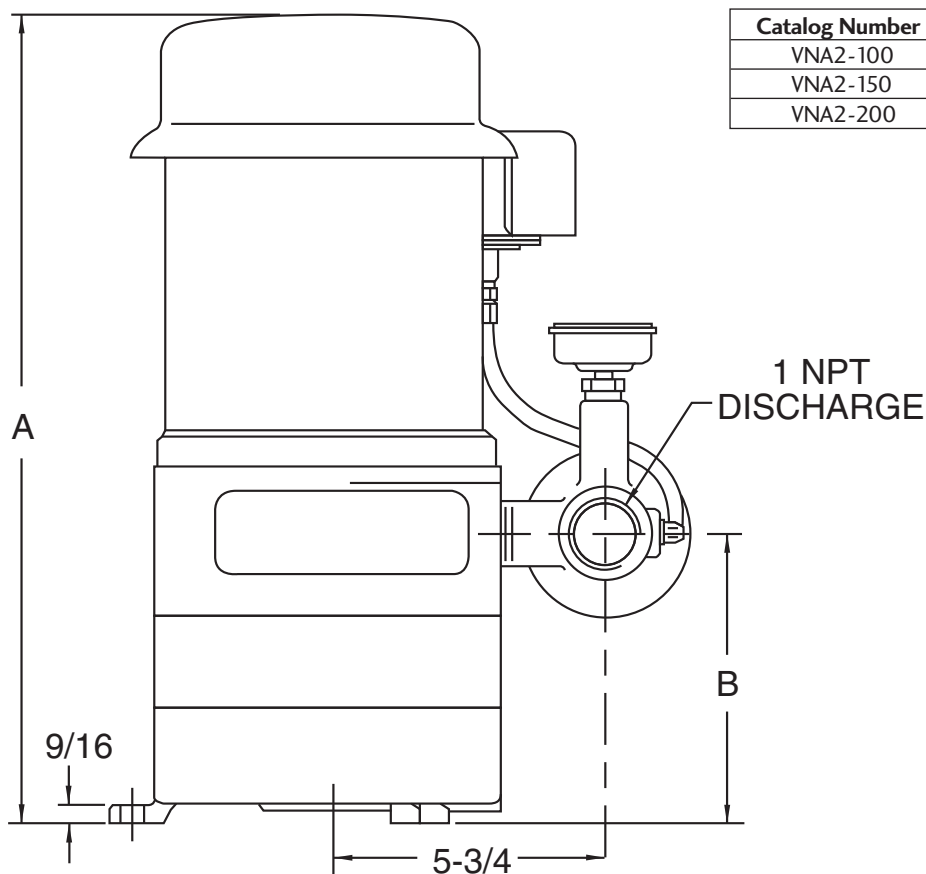

Catalog Number	A	B
VNA2-100	18-3/8	5-5/8
VNA2-150	20-7/16	7-1/2
VNA2-200	20-15/16	7-1/2

Dimensions (in inches) are for estimating purposes only.

VNA2 series

pump performance – deep well (40 PSI) 4" double pipe

Pumping capacities in gallons per minute at vertical depth to pumping level.

HP	Pump Model	Jet No.	Uses Venturi	Uses Nozzle	Pumping Depth in Feet																		Max. Pump Shut Off Press. (PSI)																		
					30'	40'	50'	60'	70'	80'	90'	100'	110'	120'	130'	140'	180'	200'	220'	240'	260'	280'	300'	320'	Jet at Min. Depth	Jet at Max. Depth															
					1	VNA2-100	23SD	J32P-24	J34P-42	12.1	11.7	11.6	11.1	10.2	9.2	7.8	6.4	5.0	4.0	3.0																					
15SD	J32P-18	J34P-42	5.5	5.5	5.5		5.4	5.3	5.3	5.2	5.1	5.1	5.0	4.8	4.5	3.3	2.7	2.0	1.3	1.0																		200	97		
1-1/2	VNA2-150	23SD	J32P-24	J34P-42	12.2	12.2	12.2	12.2	11.7	11.3	10.7	9.9	9.0	8.3	7.0	4.0	1.3																						164	95	
		15SD	J32P-18	J34P-42	5.5	5.5	5.5	5.5	5.5	5.5	5.3	5.3	5.2	5.1	5.1	5.0	4.8	4.7	4.5	4.3	4.0	3.3	2.7																314	172	
2	VNA2-200	23SD	J32P-24	J34P-42	12.2	12.2	12.2	12.2	11.8	11.3	11.2	11.1	11.0	10.0	8.7	7.0	4.0	2.0																						195	110
		15SD	J32P-18	J34P-42	5.5	5.5	5.5	5.5	5.5	5.5	5.3	5.3	5.2	5.1	5.1	5.0	5.0	4.8	4.8	4.5	4.3	4.0	3.3	2.7															314	172	

pump performance – deep well (40 PSI) 2" single pipe

Pumping capacities in gallons per minute at vertical depth to pumping level.

HP	Pump Model	Jet No.	Uses Venturi	Uses Nozzle	Pumping Depth in Feet																		Max. Pump Shut Off Press. (PSI)																			
					30'	40'	50'	60'	70'	80'	90'	100'	110'	120'	130'	140'	180'	200'	220'	240'	260'	Jet at Min. Depth	Jet at Max. Depth																			
					1	VNA2-100	12AP	J32P-24	J34P-42	12.1	11.3	11.2	10.0	8.8	7.6	6.5	5.6	3.3	1.8																							
8AP	J32P-18	J34P-18	5.5	5.5	5.3		5.3	5.2	5.1	5.0	5.0	5.0	5.0	4.5	4.2	2.0																							198	126		
1-1/2	VNA2-150	12AP	J32P-24	J34P-42	12.2	12.0	12.0	12.0	11.5	11.2	9.7	8.3	6.8	5.5	4.2	3.3																									162	110
		8AP	J32P-18	J34P-18	5.5	5.5	5.5	5.5	5.5	5.3	5.2	5.1	5.0	5.0	5.0	4.8	4.3	3.5	2.7	1.7																				266	158	
2	VNA2-200	12AP	J32P-24	J34P-42	12.2	12.0	12.0	12.0	11.7	11.2	11.0	10.3	8.3	7.5	6.3	5.3																									193	139
		8AP	J32P-18	J34P-18	5.5	5.5	5.5	5.5	5.5	5.3	5.2	5.2	5.1	5.1	5.0	4.8	4.7	4.3	3.7	3.2	2.5																			312	192	

pump performance – deep well (40 PSI) 3" single pipe

Pumping capacities in gallons per minute at vertical depth to pumping level.

HP	Pump Model	Jet No.	Uses Venturi	Uses Nozzle	Pumping Depth in Feet																		Max. Pump Shut Off Press. (PSI)																					
					30'	40'	50'	60'	70'	80'	90'	100'	110'	120'	130'	140'	180'	200'	220'	240'	260'	280'	300'	320'	Jet at Min. Depth	Jet at Max. Depth																		
					1	VNA2-100	23CP	J32P-24	J34P-42	12.1	11.7	11.6	11.1	10.2	9.2	7.8	6.4	5.0	4.0	3.0																								
16CP	J32P-18	J34P-42	5.5	5.5	5.5		5.4	5.3	5.3	5.2	5.1	5.1	5.0	4.8	4.5	3.3	2.7	2.0	1.3	1.0																					200	97		
1-1/2	VNA2-150	23CP	J32P-24	J34P-42	12.2	12.2	12.2	12.2	11.7	11.3	10.7	9.9	9.0	8.3	7.0	4.0	1.3																										164	95
		22CP	J32P-20	J34P-42	7.7	7.7	7.7	7.5	7.5	7.4	7.3	7.3	7.2	7.2	7.0	7.0	4.3	4.0	3.2	2.2																						210	110	
		16CP	J32P-18	J34P-42	5.5	5.5	5.5	5.5	5.5	5.5	5.3	5.2	5.2	5.1	5.0	5.0	4.9	4.7	4.0	3.8	3.0	2.3	1.7																		268	132		
2	VNA2-200	23CP	J32P-24	J34P-42	12.2	12.2	12.2	12.2	11.8	11.3	11.2	11.1	11.0	10.0	8.7	7.0	4.0	2.0																									195	110
		22CP	J32P-20	J34P-42	7.7	7.7	7.7	7.5	7.5	7.4	7.3	7.3	7.2	7.2	7.0	7.0	5.3	5.0	4.7	4.0	3.0	2.2																				250	128	
		16CP	J32P-18	J34P-42	5.5	5.5	5.5	5.5	5.5	5.5	5.3	5.3	5.2	5.1	5.1	5.0	5.0	4.8	4.7	4.5	4.3	4.0	3.3	2.7																		314	172	

Tested and rated in accordance with Water Systems Council Standards.

NOTE: Pumps installed with a PRO-Source™ tank require a 100 PSI relief valve. Pumps installed with a conventional tank require a 75 PSI relief valve. Relief valve must be capable of relieving entire flow of pump at relief pressure.