

PRO-Source PLUS™ premium steel pressurized water system tanks

- **Stainless Steel Service Connection** – “The Professional’s Choice”
- **Metal Air Valve Assembly** – “Field-Serviceable”
- **125 PSI Maximum Operating Pressure** – Four Sizes: C-PSP120, C-PSP200, C-PSP220, and C-PSP320



application

- Residential Water Systems
- Industrial, Commercial and Agricultural

specifications

Shell – Heavy gauge steel

Base – High-impact composite, ABS

Finish – Electrostatically applied, baked-on polyester paint

Water Cell – One piece seamless PVC, made from FDA listed material

Flange – 304SS

Service Connection – NPT threads, integral to flange

Air Valve – Nickel-plated brass, threaded for ease of service

certification



UL Classified to ANSI/NSF 61, Drinking Water System Components – Health Effects

- ▶ **Service Connection** – 304 stainless steel
- ▶ **Air Valve** – Nickel-plated brass
- ▶ **Maximum Operating Pressure** – 100 PSI on 16” and 20” tanks; 125 PSI on 24” tanks
- ▶ **Heavy Gauge Metal Construction** – Sturdy “welded wrapper and head design.” Built to last.
- ▶ **Polyester Paint Finish** – Electrostatically powder painted, then oven baked for a smooth high-gloss, appliance-quality finish. Resists corrosion.
- ▶ **Elongated, Seamless Water Cell** –
 - Controlled 2-dimensional cell expansion
- Rugged, seamless “water cell” prevents the most common cause of pump failure – “waterlogging”
- Water never touches the steel tank material
- Translucent bag material facilitates manufacturing quality control inspection
- ▶ **NEW Stainless Service Connection** –
 - Corrosion-resistant
 - Stainless steel – the professional’s choice
- ▶ **Integral Stand Pipe** – Promotes complete flushing of the water entering/exiting the tank
- ▶ **Nitrogen-Rich Precharge** – Decreases air permeation three to four times over straight air precharge
- ▶ **40 PSI Precharge** – Ready for use with 40/60 pressure range systems. Enables installer to reduce pressure depending on pressure switch setting
- ▶ **Sturdy Base** – Tested-tough composite construction
- ▶ **Five Year Warranty** – Managed and provided by WICOR Industries, the only U.S. pump manufacturer to design and manufacture fibre-wound and steel tanks!

PRO-Source PLUS™ is a trademark of WICOR Industries.

PRO-Source PLUS™ premium steel pressurized water system tanks

ordering information

Catalog Number	Maximum Capacity gal/liter	Diameter* inch/cm	Height* inch/cm	Precharge PSI/kPa	Connection Size Female	Drawdown in Gallons/Liter			Weight lbs/kg	Maximum Operating PSI
						20-40	30-50	40-60		
C-PSP42S-T02	19 / 72	20 / 51	21 / 53.3	40 / 276	1" NPT	6.9 / 26.1	5.8 / 21.9	5.0 / 18.9	49 / 22.2	100
C-PSP42T-T02	19 / 72	16 / 40.6	27.5 / 70	40 / 276	1" NPT	6.9 / 26.1	5.8 / 21.9	5.0 / 18.9	44 / 20.0	100
C-PSP75T-T03	32 / 121	16 / 40.6	43 / 109	40 / 276	1" NPT	11.6 / 43.9	9.8 / 37.1	8.5 / 32.2	60 / 27.2	100
C-PSP82T-T05	35 / 133	20 / 51	33 / 84	40 / 276	1" NPT	12.7 / 48.1	10.7 / 40.5	9.3 / 35.2	70 / 31.8	100
C-PSP120-T50	50 / 189	24 / 61	32.5 / 83	40 / 276	1-1/4" NPT	18.3 / 69.3	15.5 / 58.7	13.4 / 50.7	88 / 39.9	125
C-PSP200-T51	62 / 235	24 / 61	39.5 / 100	40 / 276	1-1/4" NPT	21.4 / 81.0	18.3 / 69.3	16.0 / 60.6	116 / 52.6	125
C-PSP220-T52	85 / 322	24 / 61	51 / 130	40 / 276	1-1/4" NPT	30 / 113.6	26 / 98.4	22 / 83.3	128 / 58.1	125
C-PSP320-TR50	119 / 450	24 / 61	68 / 173	40 / 276	1-1/4" NPT	41.3 / 156.3	35.4 / 134.0	31.0 / 117.3	140 / 63.5	125

*Subject to change without notice.

Maximum Liquid Temperature: 120°F (49°C)

Maximum External (Ambient) Temperature: 125°F (52°C)

tank selection chart

Pump GPM	System Pressure Switch Setting – PSI					
	20-40		30-50		40-60	
	Run Times					
	1 Minute	2 Minute	1 Minute	2 Minute	1 Minute	2 Minute
5	C-PSP42T	C-PSP75T	C-PSP42T	C-PSP82T	C-PSP42T	C-PSP82T
7-1/2	C-PSP75T	C-PSP82T	C-PSP75T	C-PSP120	C-PSP75T	C-PSP200
10	C-PSP75T	C-PSP200	C-PSP82T	C-PSP200	C-PSP82T	C-PSP220
12-1/2	C-PSP82T	C-PSP200	C-PSP120	C-PSP220	C-PSP120	C-PSP220
15	C-PSP120	C-PSP220	C-PSP120	C-PSP120 (2)	C-PSP200	C-PSP200 (2)
20	C-PSP200	C-PSP200 (2)	C-PSP200	C-PSP200 (2)	C-PSP220	C-PSP220 (2)
30	C-PSP220	C-PSP220 (2)	C-PSP120 (2)	C-PSP220 (2)	C-PSP200 (2)	C-PSP220 (3)
50	C-PSP200 + C-PSP220	C-PSP220 (3)	C-PSP220 (2)	C-PSP220 (4)	C-PSP220 (2)	C-PSP220 (5)
50	-	C-PSP320 (2) + C-PSP200	-	C-PSP320 (3)	C-PSP320 (2)	C-PSP320 (4)

NOTE: Drawdown will be affected by operating temperature of the system, accuracy of the pressure switch and gauge, the actual precharge pressure, and rate of fill.

Pumps installed with a PRO-Source PLUS™ tank require a relief valve equal to the tank's maximum operating pressure. Relief valve must be capable of relieving entire flow of pump at relief pressure.

drawdown volume multiplier* (approx.)

Pump Off Pressure PSI	Pump Start Pressure – PSI							
	10	20	30	40	50	60	70	80
20	0.26							
30	0.41	0.22						
40		0.37	0.18					
50		0.46	0.31	0.15				
60			0.40	0.27	0.13			
70			0.47	0.35	0.24	0.12		
80				0.42	0.32	0.21	0.11	
90				0.48	0.38	0.29	0.19	0.10
100					0.44	0.35	0.26	0.17

*Utilize this chart if proper selection cannot be made using tank selection chart. Drawdown based on Boyle's Law.

tank sizing rule

Size tank for one gallon of drawdown for each gallon per minute at pump capacity.

EXAMPLE: For a 1 HP, 20 GPM unit pumping 20 gallons per minute on a 30-50 pressure switch setting, the properly sized PRO-Source PLUS™ tank is a C-PSP220-T52, which has a 26 gallon drawdown.

PROCEDURE:

1. Identify drawdown multiplier relating to specific application.
2. Insert multiplier (X) into the following formula:

$$\frac{\text{Pump GPM} \times \text{Minute Run Time}}{\text{Multiplier (X)}}$$

$$= \text{Min. Tank Capacity Required}$$

EXAMPLE:

An example of a 20 GPM pump with a minimum run time of 1 minute, installed on a 50-70 PSIG system pressure range:

$$\frac{20 \text{ GPM} \times 1 \text{ Minute}}{.24 \text{ (factor) from Drawdown Volume Multiplier chart}}$$

$$= 83.3 \text{ Minimum U.S. Gallon Tank Capacity Required}$$

Referring to "Ordering Information" chart, the model C-PSP220-T52 has the closest U.S. gallon capacity that is greater or equal to the minimum volume requirement of 83.3 U.S. gallons.

PRO-Source PLUS™ premium steel pressurized water system tanks

operating cycle

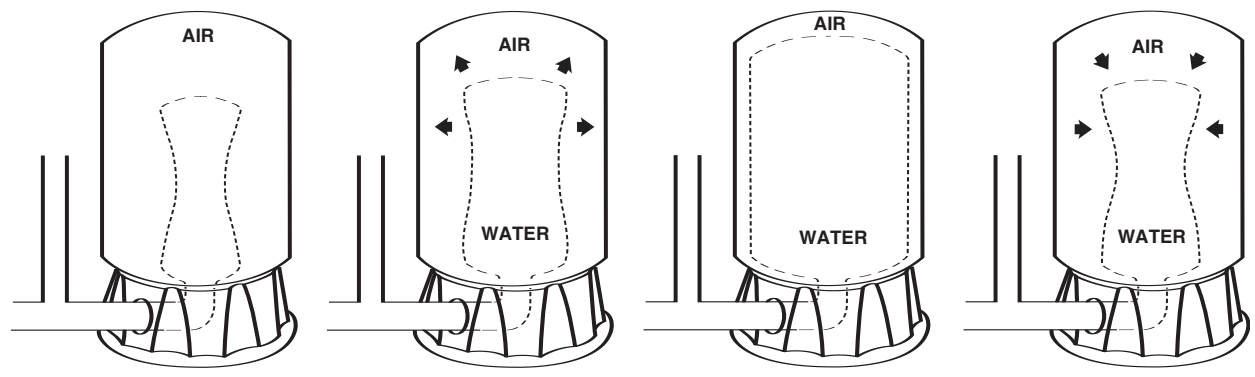

1. Separator is completely empty – A new cycle is ready to begin. Simple, positive action produces maximum drawdown on every cycle.
2. Water begins to enter the tank – Air is compressed around the water separator as it fills with water.
3. Pump up cycle completed – Air is now compressed to the cut-off setting of pressure switch.
4. Water is being drawn from the tank – Compressed air in the tank forces water out of the separator.

outline dimensions

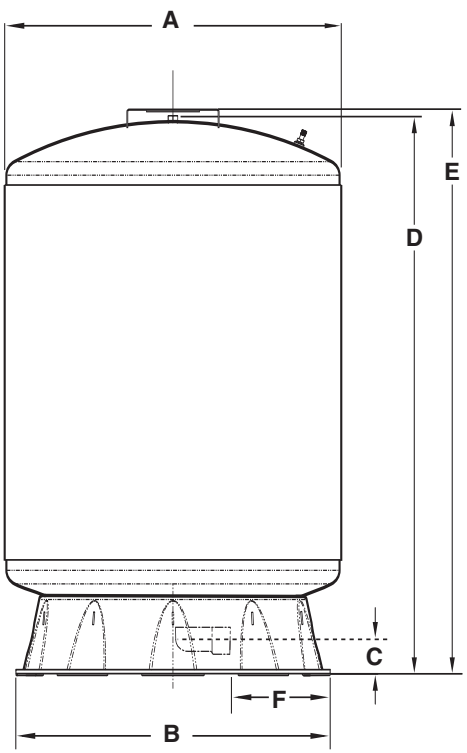

dimensional data

Catalog Number	Discharge NPT	A	B	C	D	E	F
C-PSP42T-T02	1"	16.1	15.5	2.0	27.8	–	3.9
C-PSP75T-T02	1"	16.1	15.5	2.0	43.0	–	2.3
C-PSP42S-T02	1"	20.1	15.5	2.0	–	21.5	2.3
C-PSP82T-T05	1"	20.1	15.5	2.0	33.0	–	2.3
C-PSP120-T50	1-1/4"	24.1	22.7	2.5	33.2	–	5.5
C-PSP200-T51	1-1/4"	24.1	22.7	2.5	40.1	–	5.5
C-PSP220-T52	1-1/4"	24.1	22.7	2.5	51.5	–	5.5
C-PSP320-TR50	1-1/4"	24.1	22.7	2.5	68.6	–	5.5

Dimensions (in inches) are for estimating purposes only.