

PRO-Source™ steel EpoxyLined™ air-over-water tanks

The PRO-Source™ EpoxyLined™ Tank is an excellent corrosion-resistant tank available in a variety of sizes for use in water systems applications, as a retention tank or holding tank. This tank utilizes an electrostatic paint process, resulting in superior rust protection.



application

For use as a standard water tank, retention tank or holding tank.

specifications

Shell – Heavy gauge steel

Skirt – Heavy gauge steel

Interior Coating – Epoxy, baked-on

Fittings – Machined steel

Finish – Baked-on polyester paint

certification



UL Classified to ANSI/NSF Standard 61, Drinking Water System Components – Health Effects

ordering information

Catalog Number	Capacity U.S. Gal.	Style	Tank Diameter	Tank Height	Tank Length	Approx. Wt. Lbs.	Max. Oper. Press. (PSI)
AW30H	30	Horizontal	16"	17-1/2"	36-1/2"	55	75
AW42	42	Vertical	20"	36-5/8"	N/A	67	75
AW42T	42	Vertical	16"	53-1/2"	N/A	65	75
AW85	85	Vertical	24"	51"	N/A	94	75
AW120	120	Vertical	24"	68"	N/A	120	75

PRO-Source™ and EpoxyLined™ are trademarks of WICOR Industries.

- Quality Construction** – The precision press fit head and wrapper minimize the possibility of large gaps between components. This manufacturing process reduces the possibility of corrosion and seam leaks.
- Heavy Gauge Steel** – Sturdy construction is emphasized, with heavier gauge steel than most tanks. This minimizes the possibility of dents from mishandling, and rust-through.
- Uniform Epoxy Coating** – The insides of the tanks are electrostatically powder-coated and then are oven baked to ensure proper adhesion and consistent coverage. This paint process offers superior corrosion resistance over traditional wet paints.
- Appliance-like Exterior Finish** – A polyester paint is also electrostatically adhered to the outer surface and then baked on for a high-gloss appearance
- Flush Mount Fittings** – Designed to solve one of the toughest corrosion problems, these fittings eliminate flanges and sharp angles that make paint adherence difficult
- Standard Top Mount Fitting** – Facilitates use as a retention tank, or for hard-to-fit areas. This fitting can also be used for an optional jet mount package.
- Sturdy Base** – Bases for horizontal models are constructed of heavy gauge steel, with slots for ventilation to avoid condensation problems

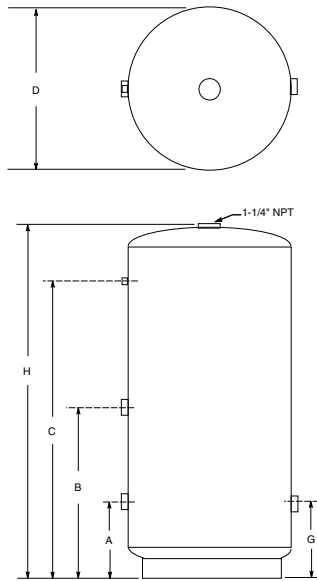
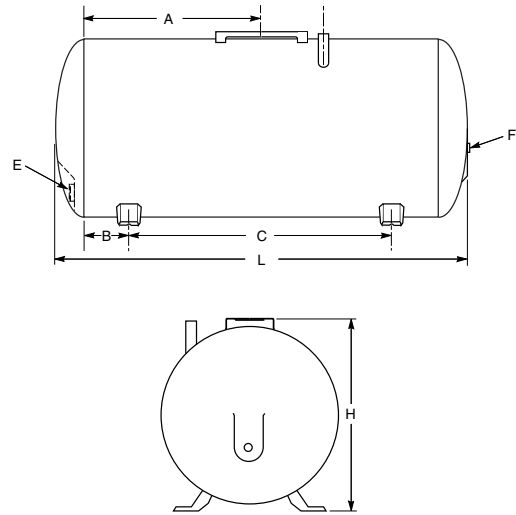
PRO-Source™ steel EpoxyLined™ air-over-water tanks
outline dimensions – vertical

outline dimensions – horizontal

Dimensions (in inches) are for estimating purposes only.

dimensional data

Catalog Number	Gallons	Dimensions in Inches									
		Dia. D	Ht. H	A Dist.	A Size	B Dist.	B Size	C Dist.	C Size	G Dist.	G Size
VERTICAL EPOXYLINED TANKS											
AW42	42	20	36-5/8	8-1/2	1-1/4	19-1/2	1-1/4	27-3/4	1/4	8-1/2	1-1/4
AW42T	42	16	53-1/2	8	1-1/4	28	1-1/4	45	1/4	8	1-1/4
AW85	85	24	51	12	1-1/4	26-1/8	1-1/4	40-7/8	1/4	9-1/2	1-1/4
AW120	120	24	68	12	1-1/4	35	1-1/4	58-1/8	1/4	9-1/2	1-1/4

Catalog Number	Gallons	Dimensions in Inches							Outlet Size	
		Dia.	Length	Ht.	A	B	C	E	F	
HORIZONTAL EPOXYLINED TANKS										
AW30H	30	16	36-1/2	17-1/2	13-3/4	4-3/4	22	3/4	1/4	

Horizontal tanks include pump mounting bracket as standard.

NOTE: All pumps installed with a PRO-Source™ tank require a 75 PSI relief valve. Relief valve must be capable of relieving entire pump flow at relief pressure.

tank performance

Catalog Number	Capacity U.S. Gal.	Drawdown in Gallons		
		20-40	30-50	40-60
AW30H	30	5.2	4.4	3.9
AW42	42	6.7	5.8	5.0
AW42T	42	6.9	5.9	5.2
AW85	85	14.3	12.3	10.7
AW120	120	19.9	17.1	14.9